

## **FRIPP ISLAND PUBLIC SERVICE DISTRICT**

### **PROCEDURES FOR TRUCKS WEIGHING MORE THAN 21 TONS CROSSING THE FRIPP ISLAND BRIDGE**

Based on the recommendation of the Fripp Island Public Service District's independent bridge engineers, the following procedures have been created for handling trucks over 21 tons that wish to use the Fripp Island bridge.

Before coming on the island, all trucks over 21 tons must be weighed. This must include total weight plus split weights both front and back. No split weight may exceed 16 tons regardless of length. These weights and the distance between axles must be phoned/faxed into the FIPSD office for approval to cross the bridge. FIPSD will determine the maximum load the truck may carry with every effort made to equalize the weight distribution. Charts in one-ton increments will be utilized for loads from 22 to 31 tons. Loads of 32 tons must be equally balanced with 16 tons in front and 16 tons in back. All charts, including a chart showing where to measure load points, are available on the District website at <http://www.fipsd.org/bridgeerosioncontrol.html>, or upon request at the District office.

Excessive vehicle loads may require shutting down all other bridge traffic to allow passage. Based on the charts mentioned above, if a load falls into the area where the bridge must be shut down, then the following procedure will apply. The driver must get permission from the FIPSD to pass over the bridge after the truck is weighed and its weight distribution is determined. The truck driver must have a cell phone and call Fripp Island Security when he is at the Hunting Island end of the bridge. Security will send someone across the bridge to check the weight tickets and then stop traffic going off the island and tell the truck driver to proceed. Copies of the weight tickets for all loads over 21 tons will be dropped off at the PSD office.

Loads over 21 tons going off the island that require the bridge to be shut down will have to coordinate with PSD and Security ahead of time so they may arrange to shut off traffic on the North end of the bridge. Due to their short wheelbase, the limit on cement trucks will remain at 21 tons.

Carolina Storage (10 Neil Rd, Beaufort, 843-524-5800) has a 70ft load cell scale and can provide certified weight tickets for a minimal fee. Pilot Travel Center at Exit 5 on Hwy. 95 is able to provide both total and split weight tickets. Truckers must show these weight tickets with dates and descriptions to Security and provide copies to the PSD office. Other certified scales may also be used.

Any loads that do not meet these requirements will be dealt with on an individual basis. Truckers who violate this policy may be fined an appropriate amount.

Fripp Island Public Service District  
291 Tarpon Blvd., Fripp Island, SC 29920  
Telephone # 843-838-2400 / Fax # 843-838-4900

Fripp Island Security—Telephone # 843-838-2334, Fax # 843-838-2101

# Fripp Island Inlet Bridge Vehicle Restrictions

**22 Ton Vehicle Weight - 3 Axle**

**By: Taylor 11/10/04**



Wilbur Smith Associates

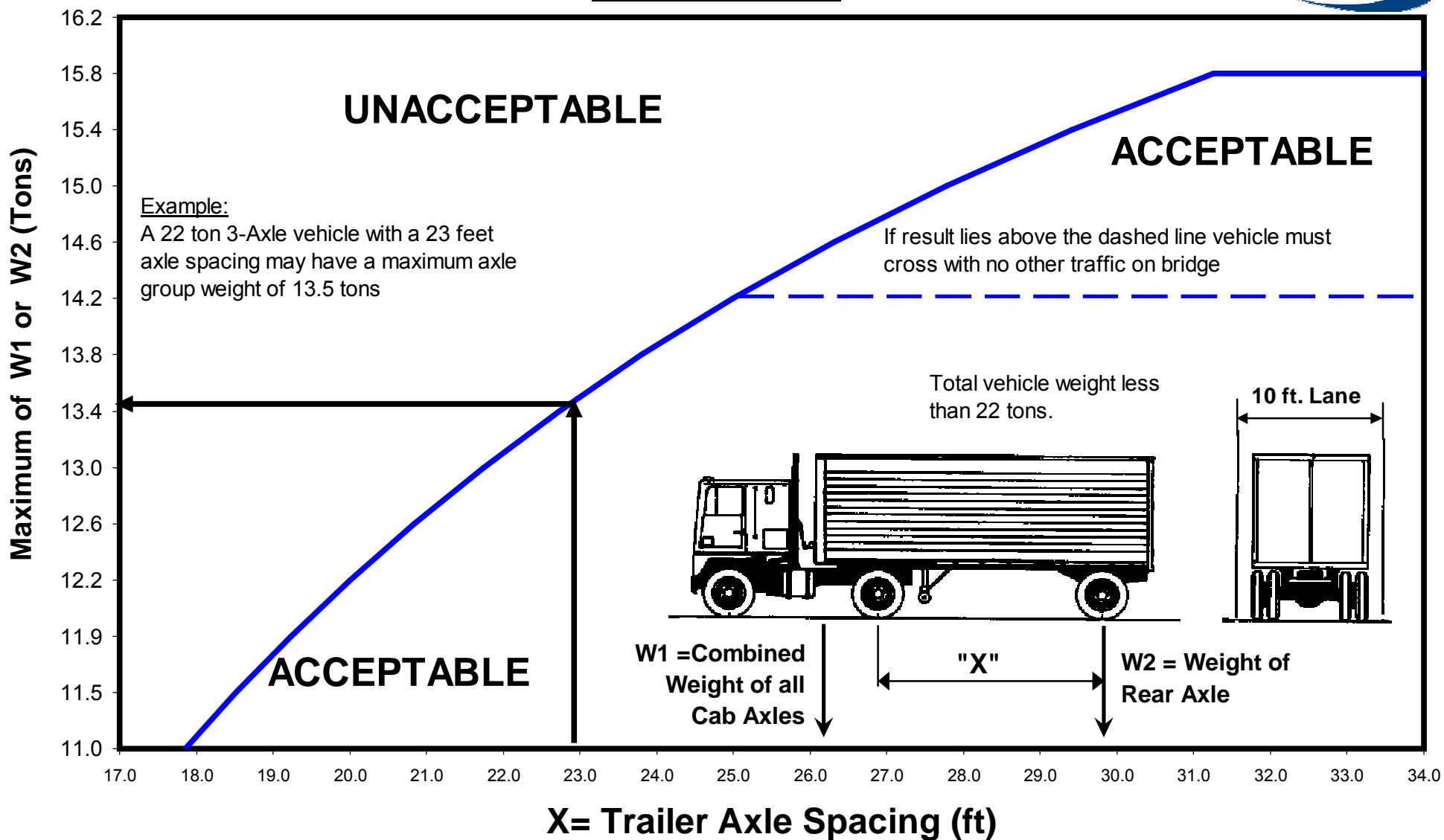

# Fripp Island Inlet Bridge Vehicle Restrictions

23 Ton Vehicle Weight - 3 Axle

By: Taylor 11/10/04



Wilbur Smith Associates

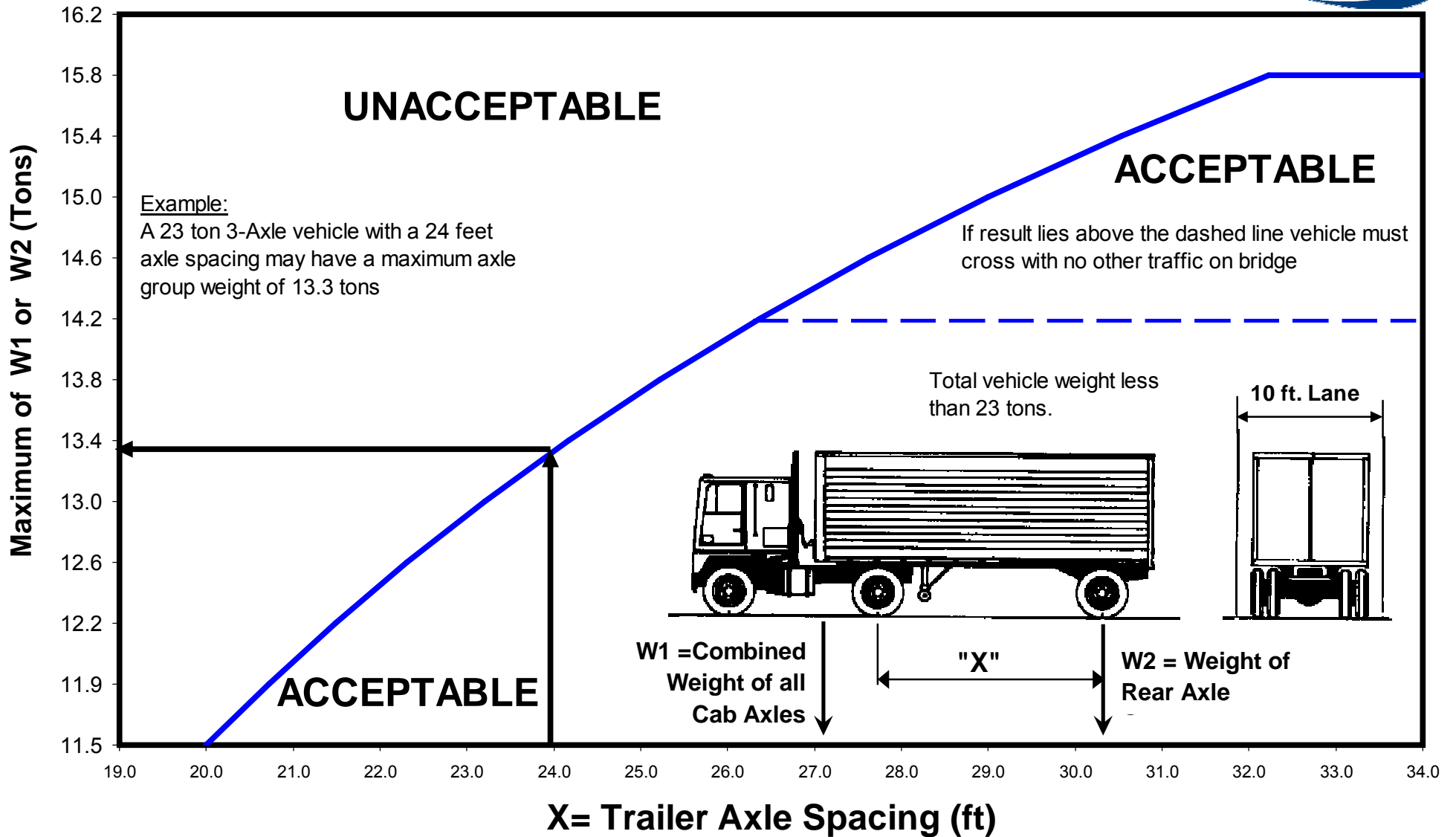

# Fripp Island Inlet Bridge Vehicle Restrictions

## 23.7 Ton Vehicle Weight - 3 Axle

By: Taylor 11/10/04



Wilbur Smith Associates

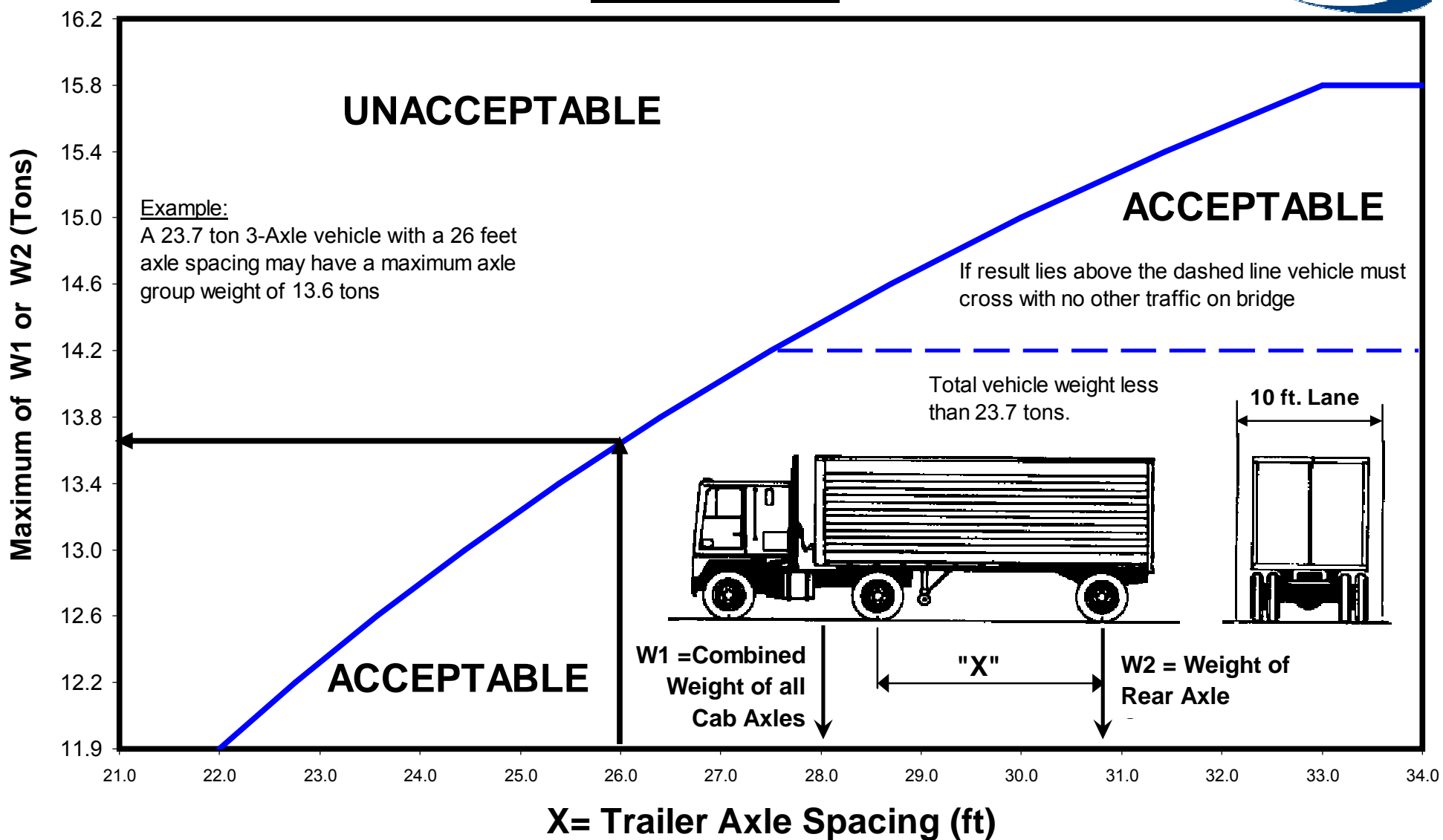

# Fripp Island Inlet Bridge Vehicle Restrictions

24 Ton Vehicle Weight - 3 Axle

By: Taylor 11/10/04



Wilbur Smith Associates

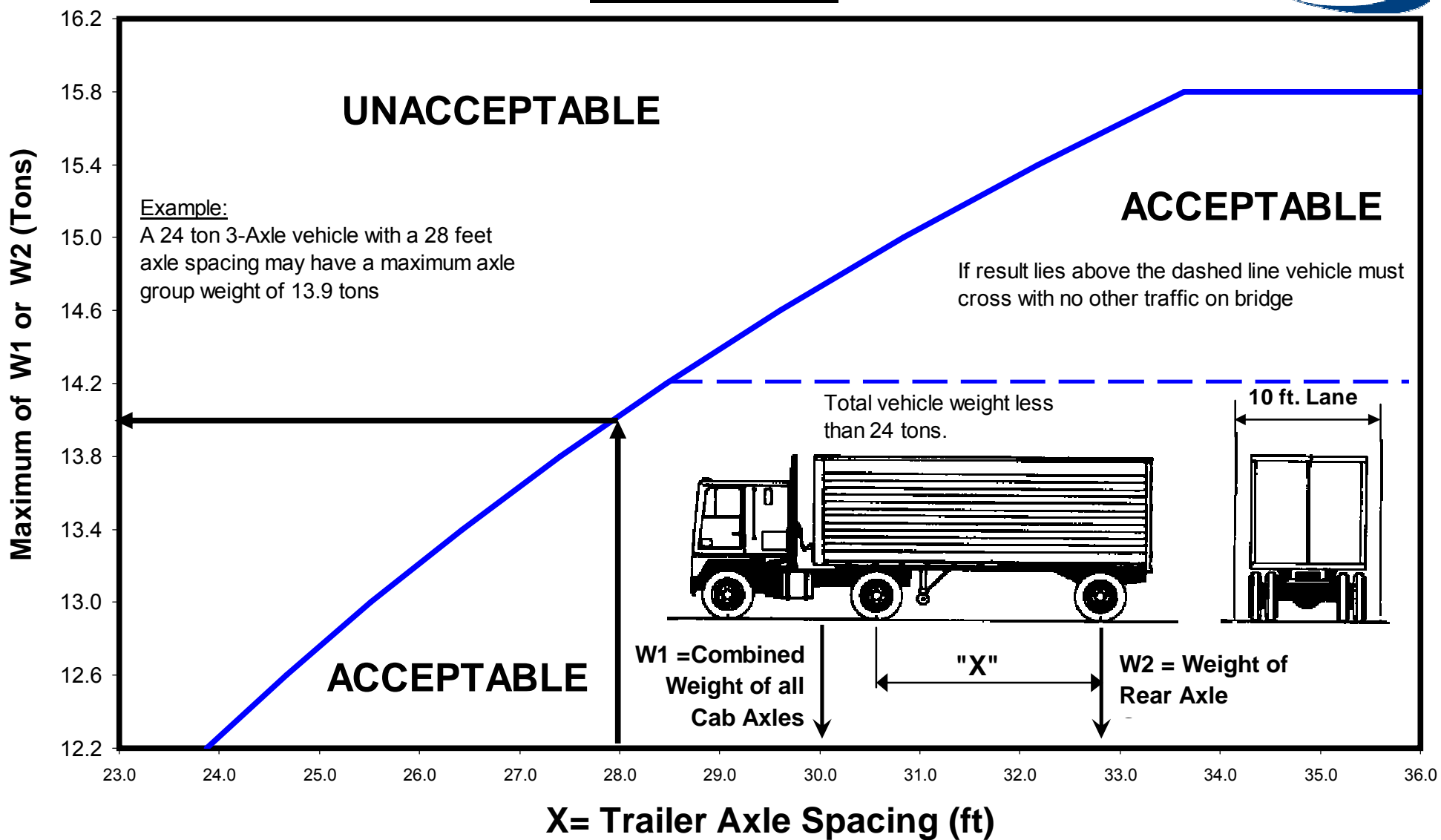

# Fripp Island Inlet Bridge Vehicle Restrictions

25 Ton Vehicle Weight - 3 Axle

By: Taylor 11/10/04



Wilbur Smith Associates

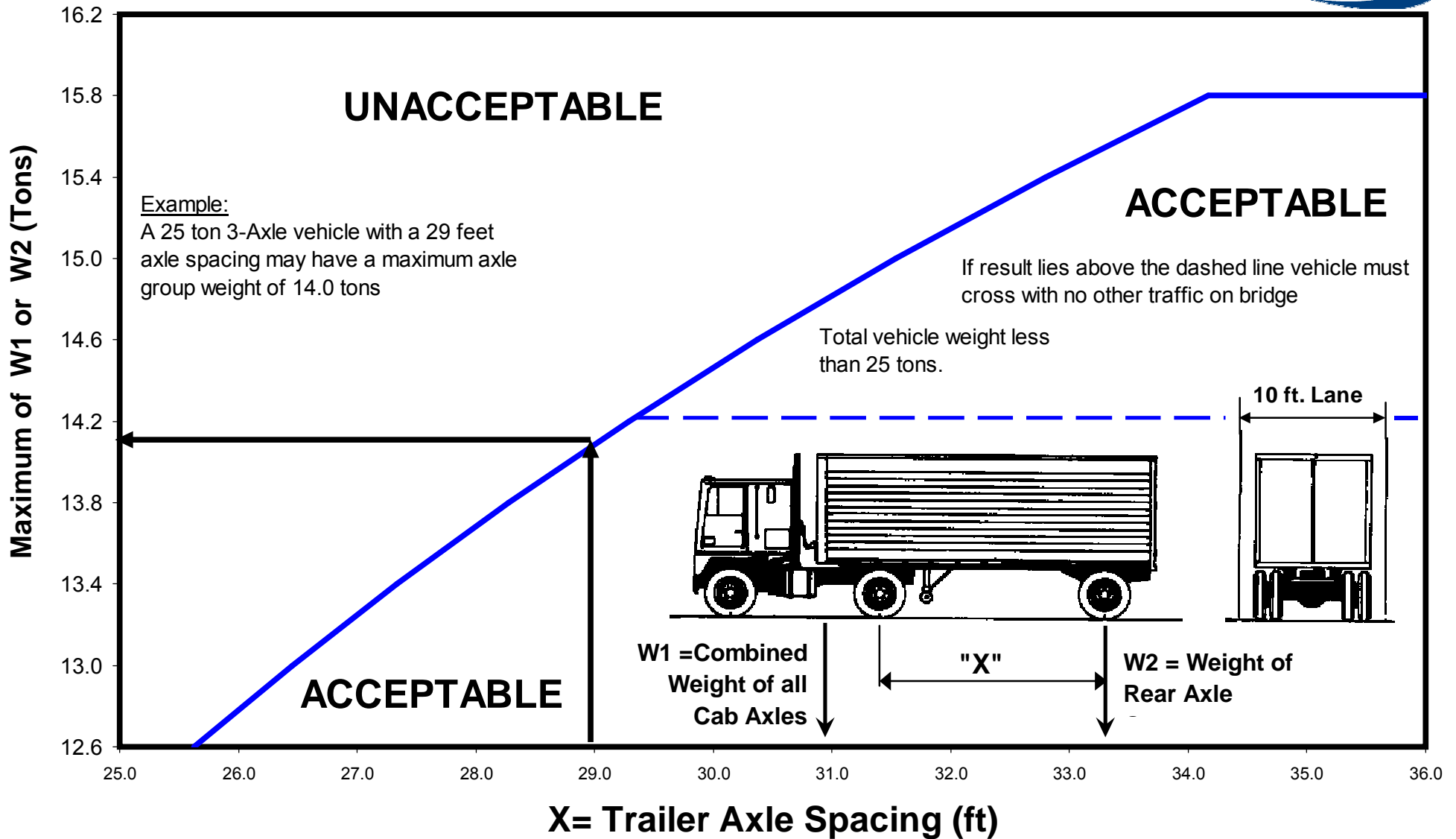

# Fripp Island Inlet Bridge Vehicle Restrictions

26 Ton Vehicle Weight - 3 Axle

By: Taylor 11/10/04



Wilbur Smith Associates

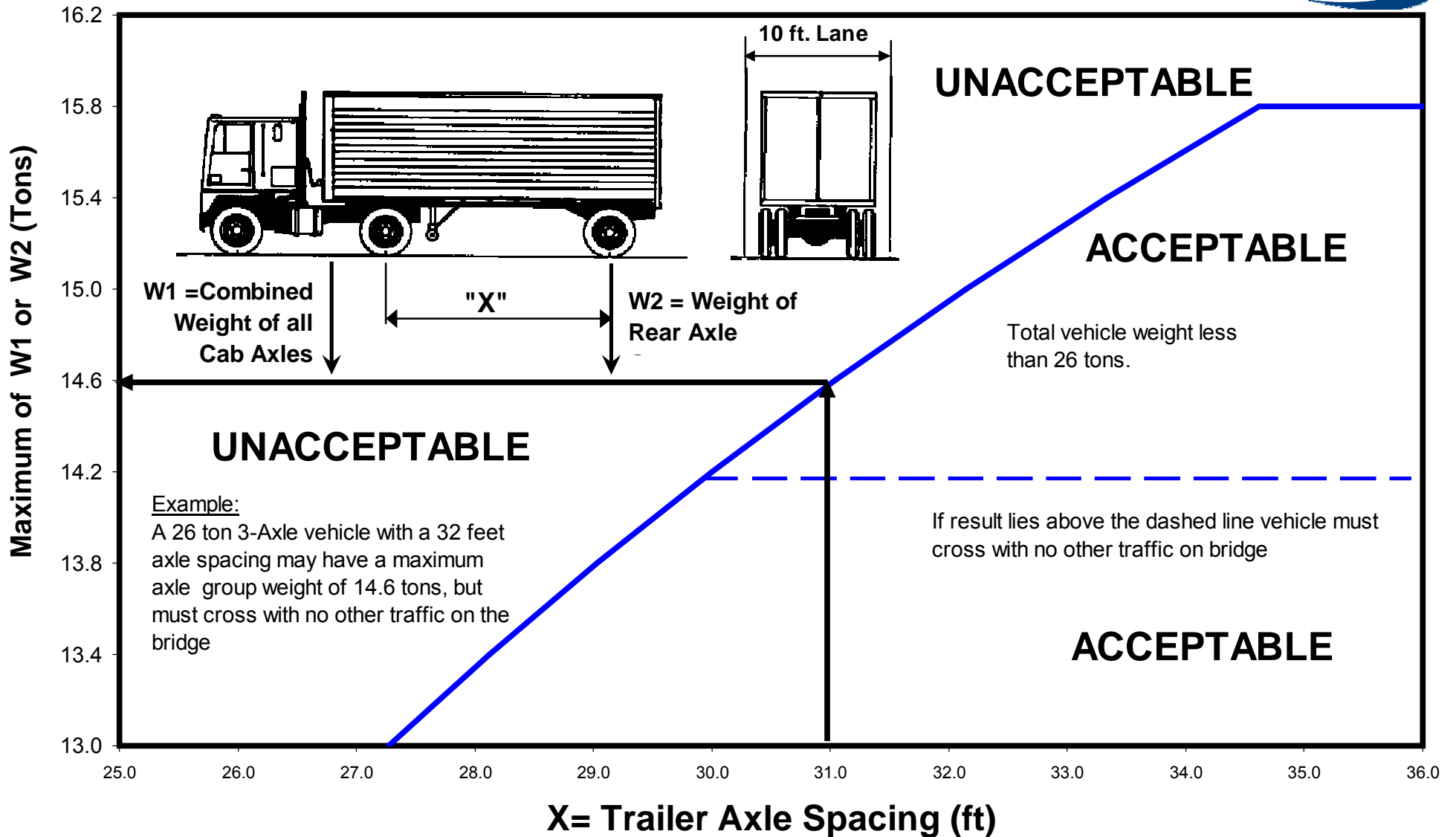

# Fripp Island Inlet Bridge Vehicle Restrictions

27 Ton Vehicle Weight - 3 Axle

By: Taylor 11/10/04



Wilbur Smith Associates

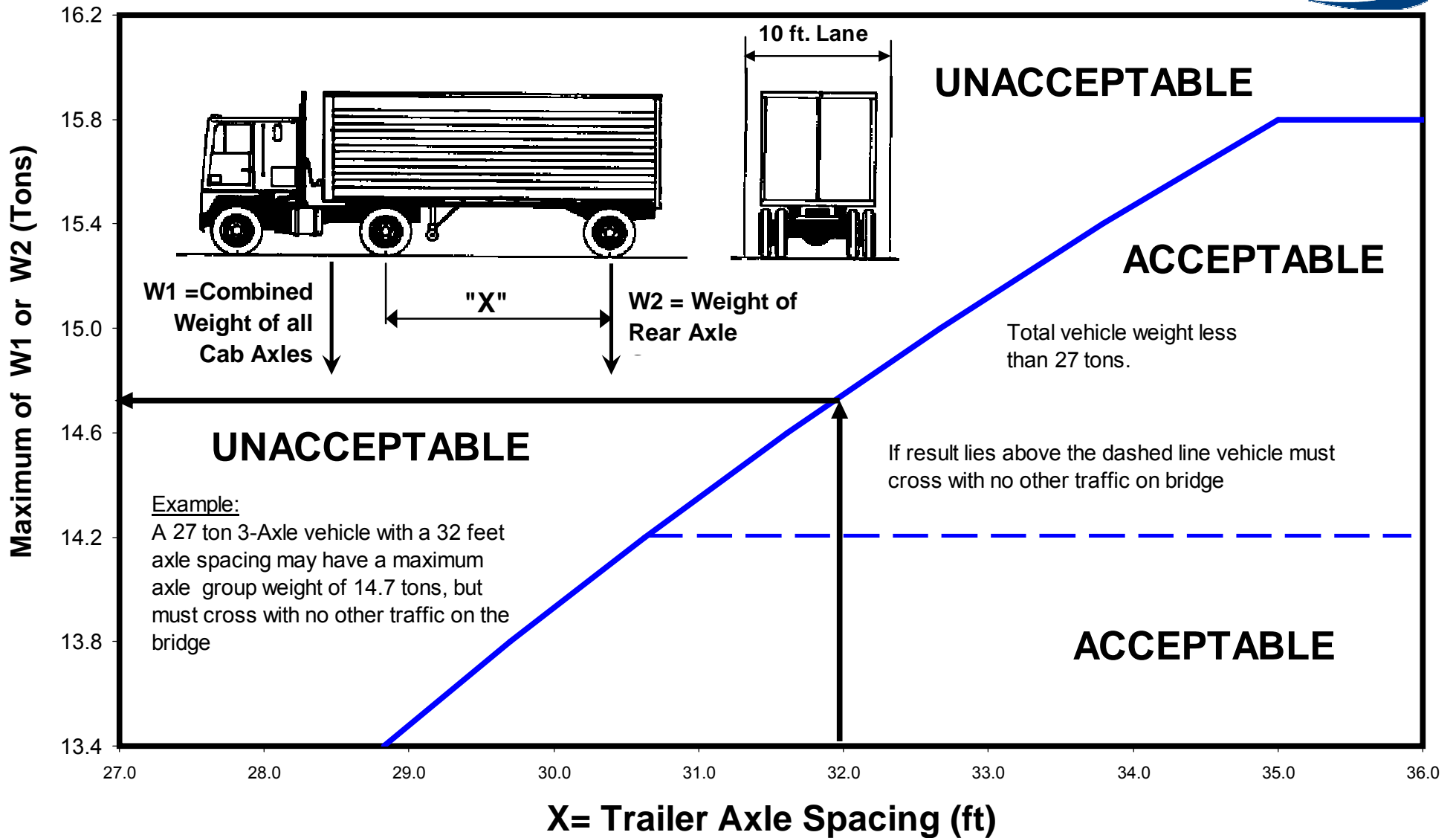



# Fripp Island Inlet Bridge Vehicle Restrictions

27.6 Ton Vehicle Weight - 3 Axle

By: Taylor 11/10/04

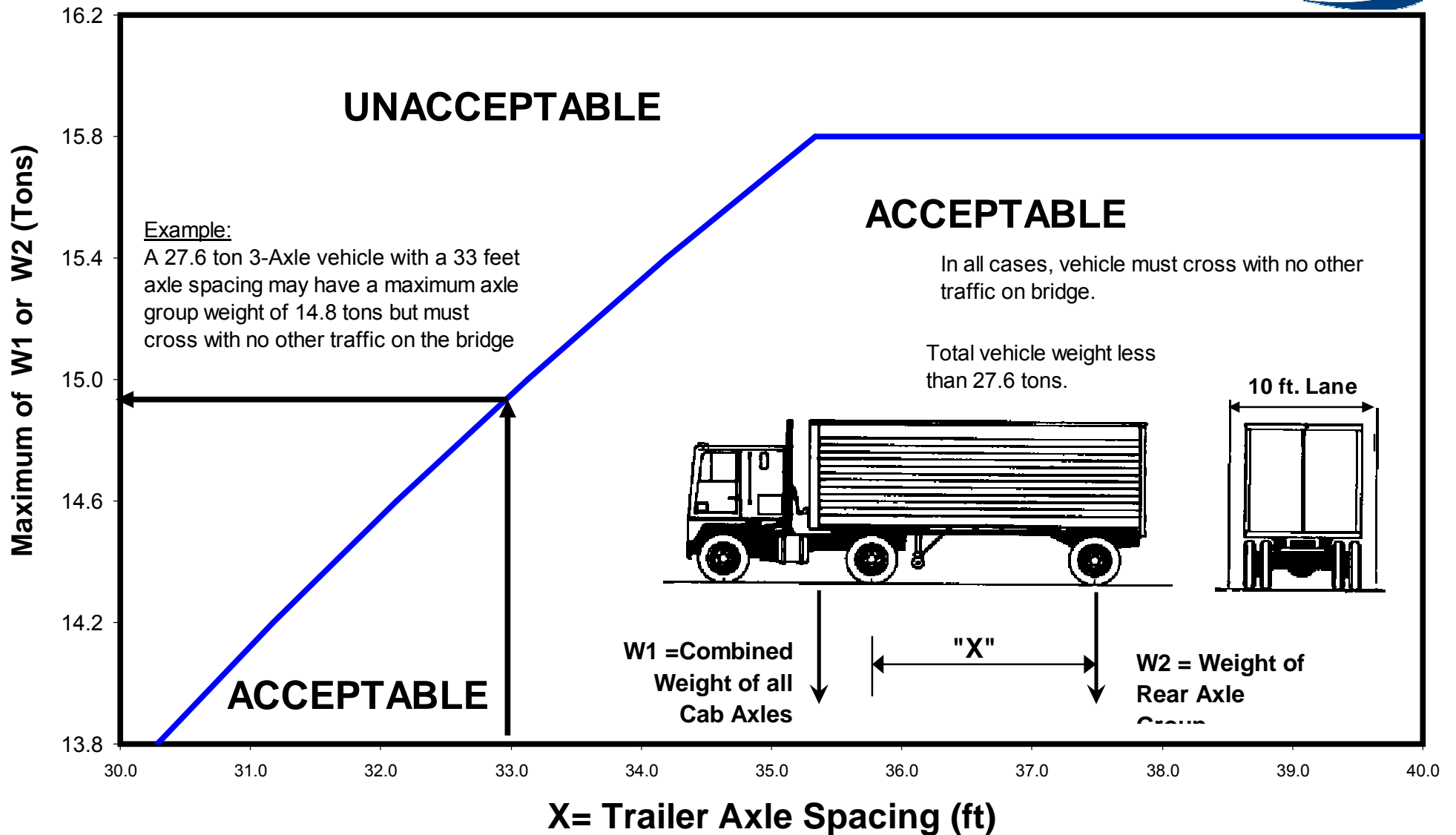

# Fripp Island Inlet Bridge Vehicle Restrictions

28 Ton Vehicle Weight - 3 Axle

By: Taylor 11/10/04

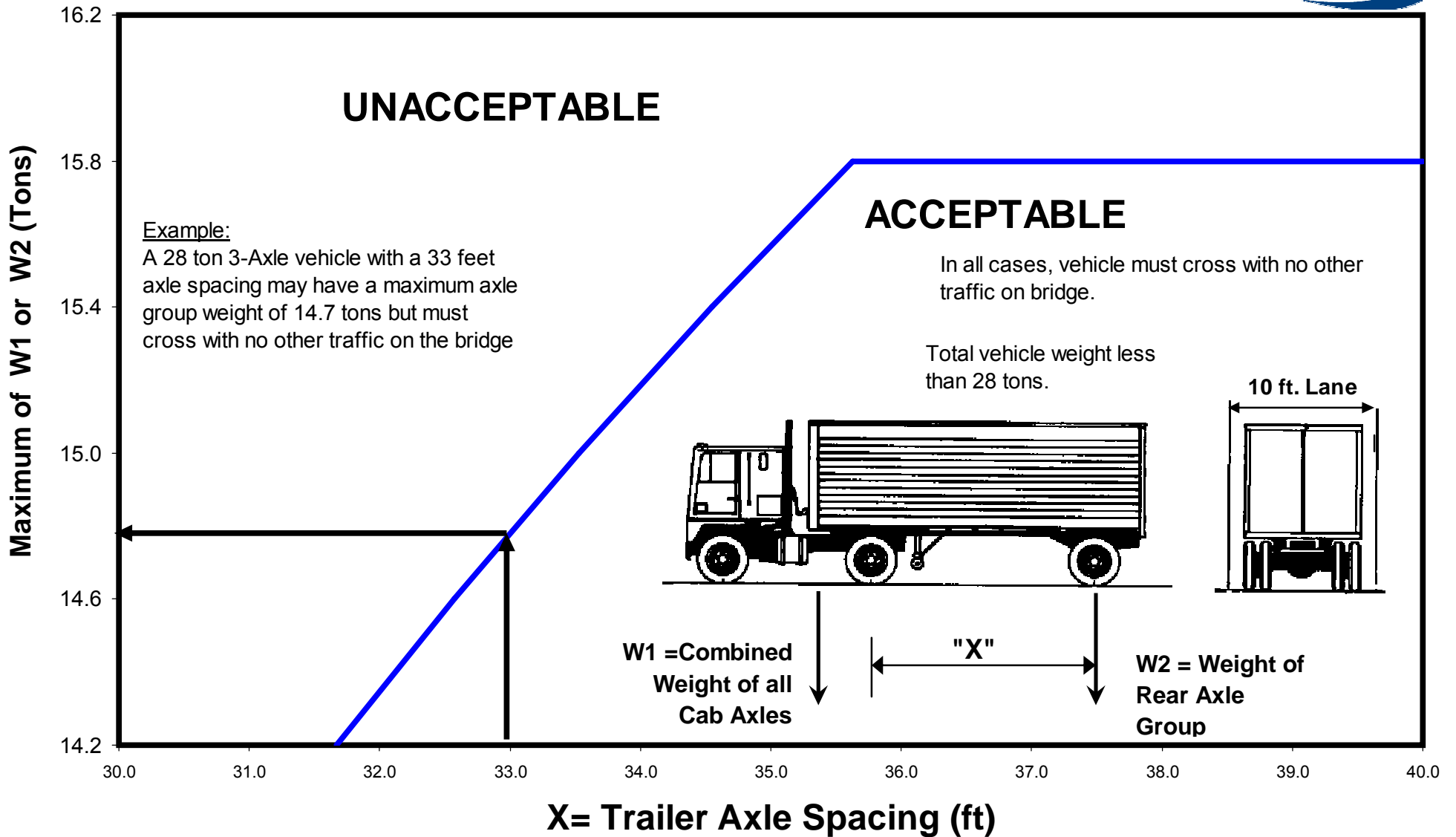

# Fripp Island Inlet Bridge Vehicle Restrictions

29 Ton Vehicle Weight - 3 Axle

By: Taylor 11/10/04



Wilbur Smith Associates

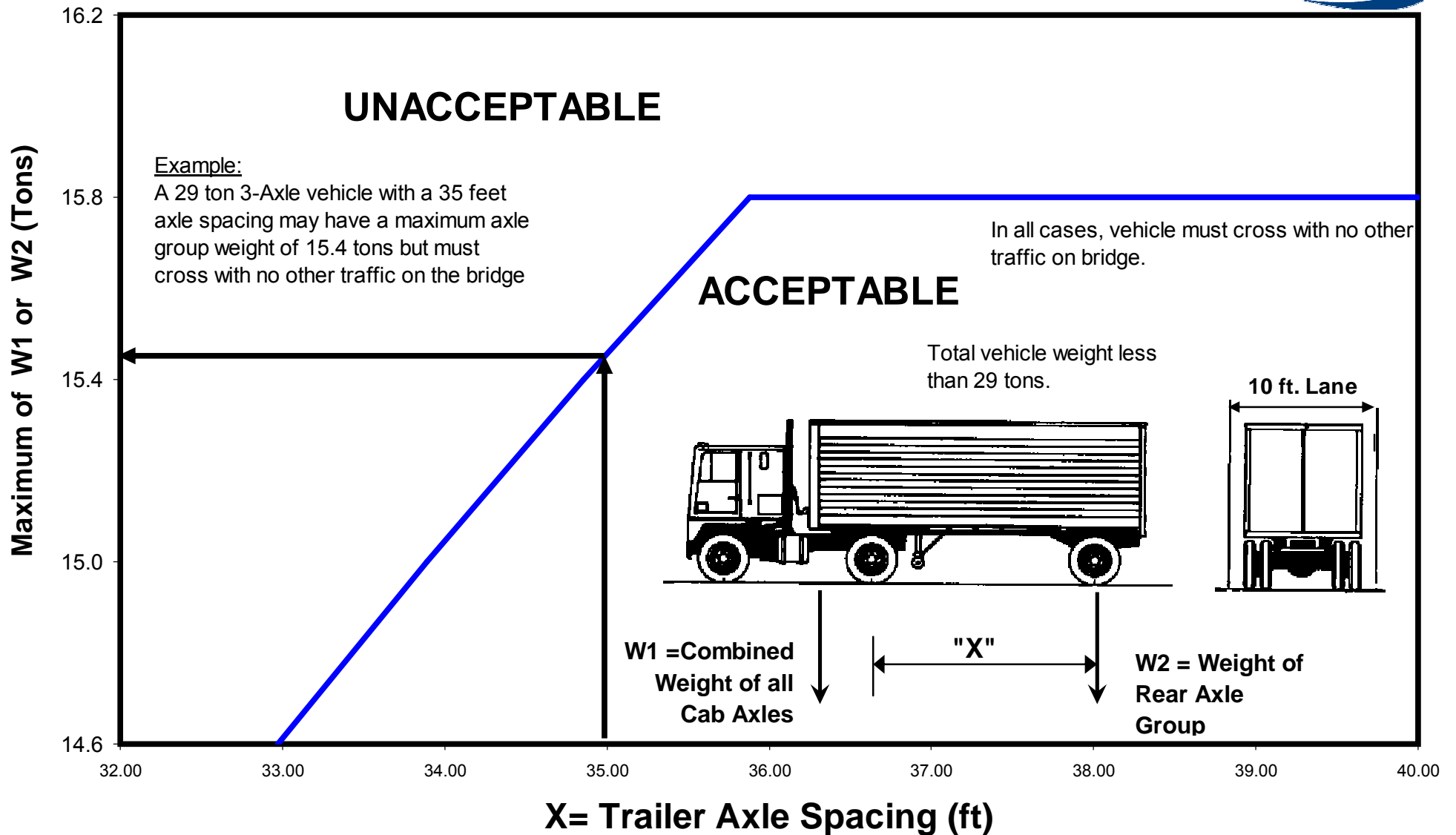

# Fripp Island Inlet Bridge Vehicle Restrictions

30 Ton Vehicle Weight - 3 Axle

By: Taylor 11/10/04

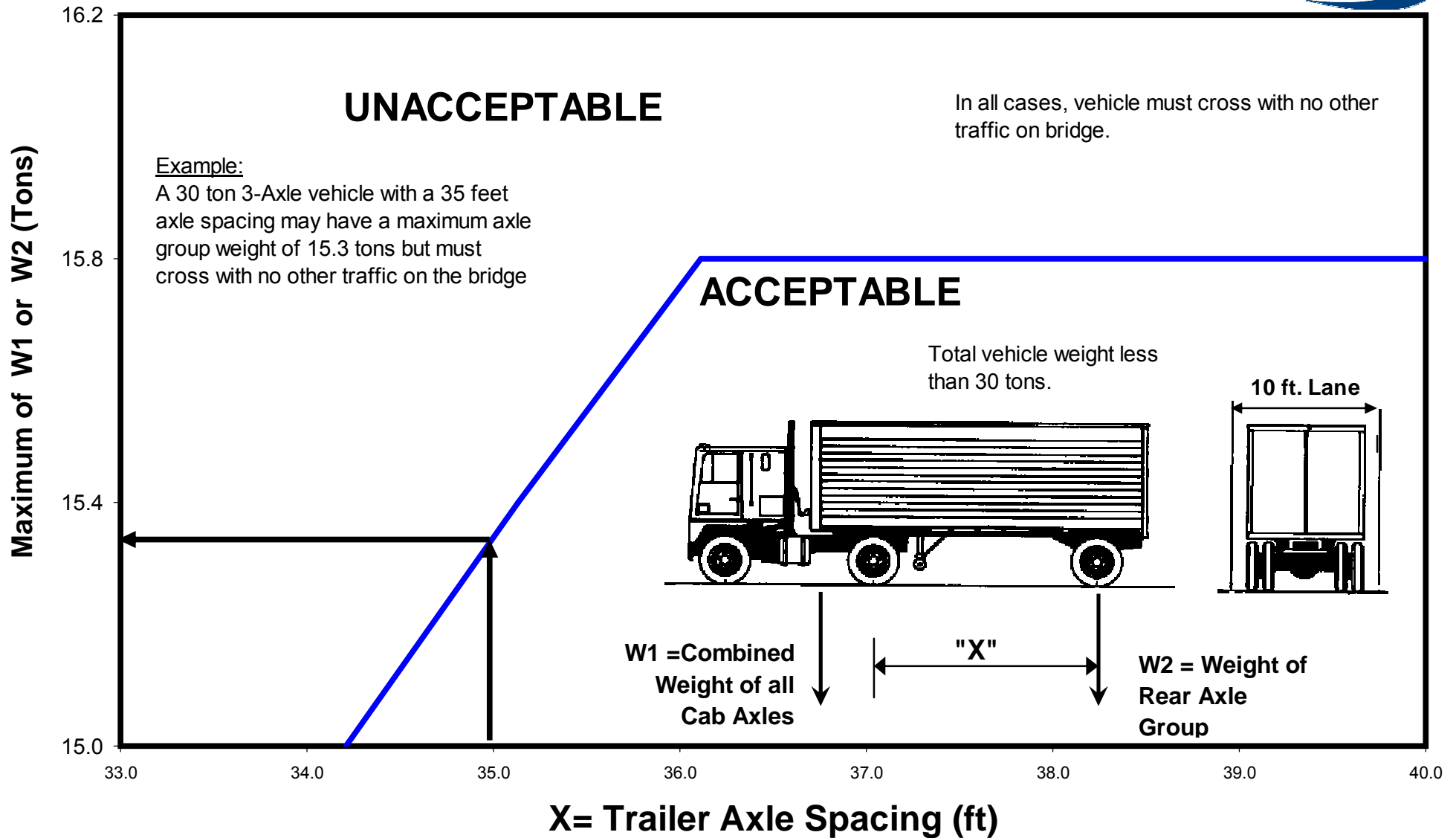

# Fripp Island Inlet Bridge Vehicle Restrictions

31 Ton Vehicle Weight - 3 Axle

By: Taylor 11/10/04



Wilbur Smith Associates

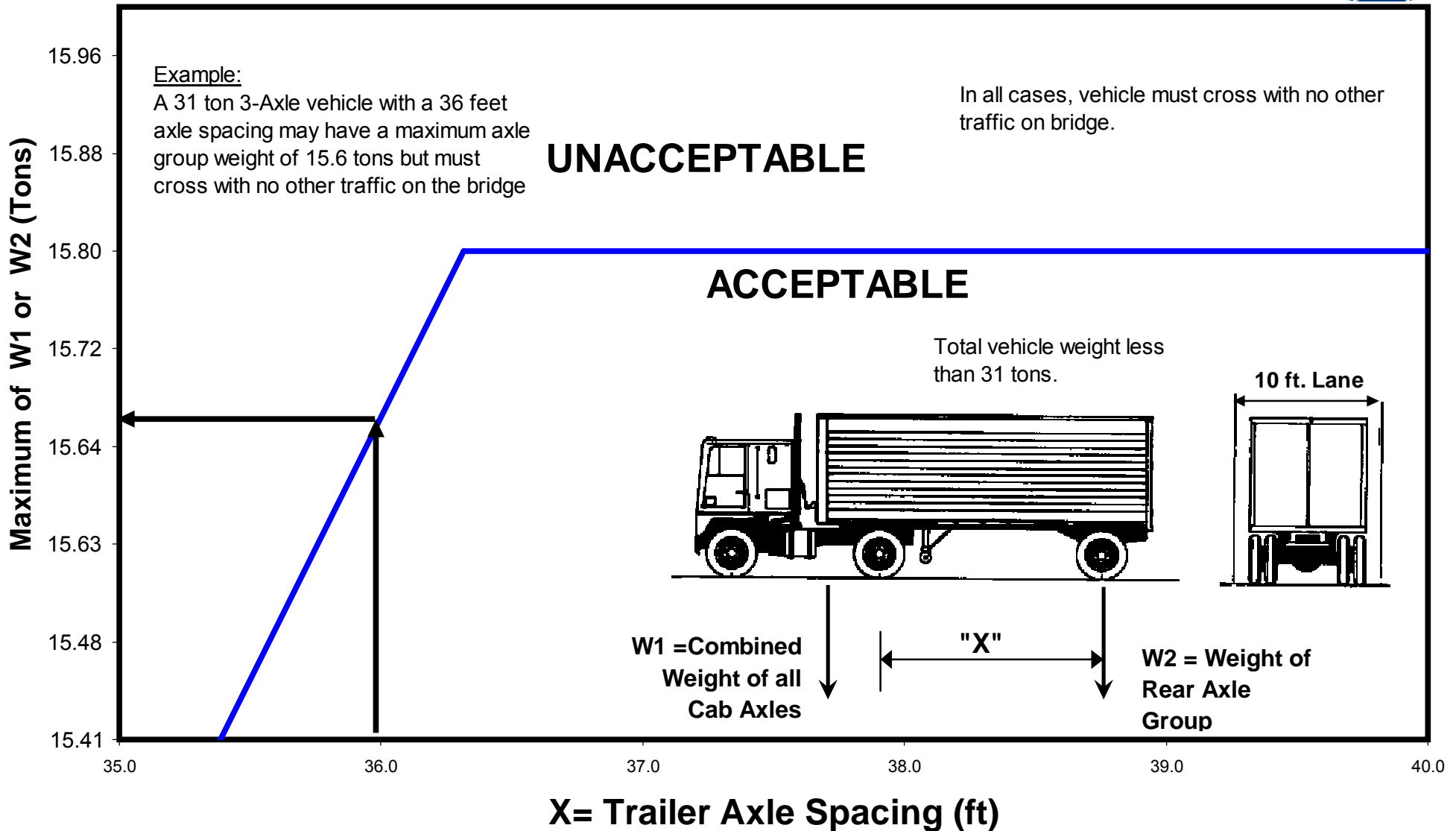

In all cases, vehicle must cross with no other traffic on bridge.

# Fripp Island Inlet Bridge Vehicle Restrictions

BY: Taylor    Date: 11/04

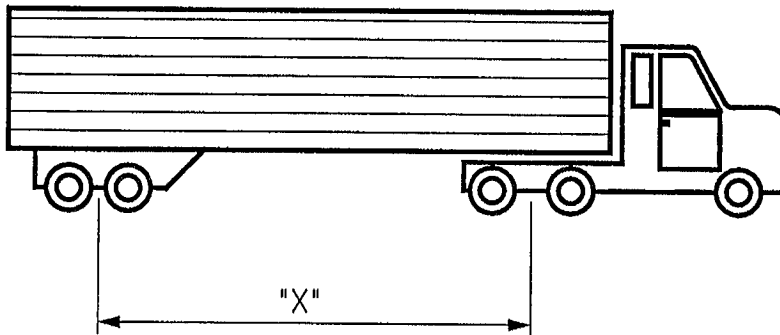
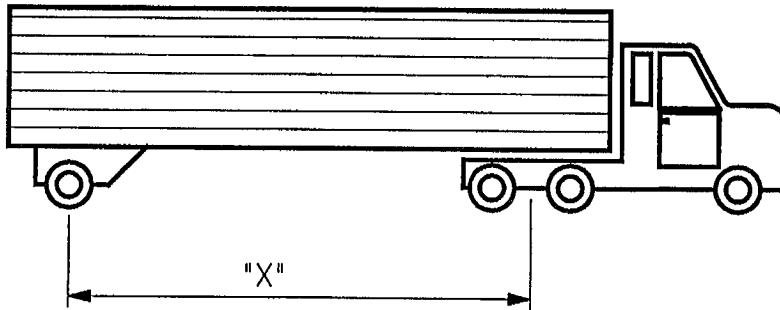
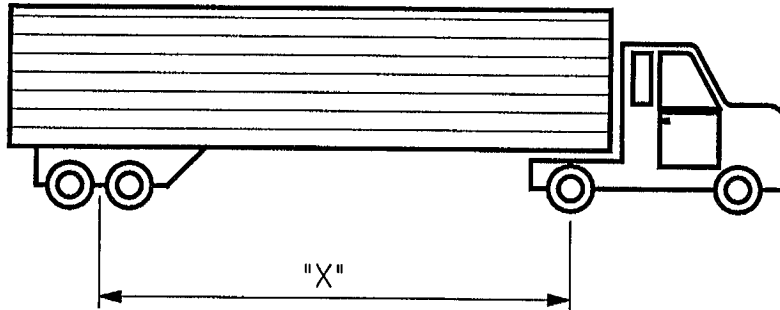
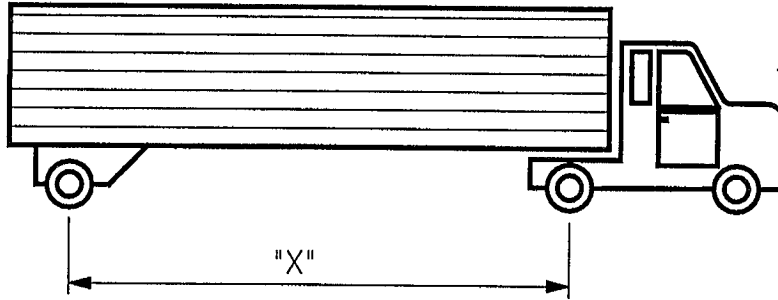

Measurement of Dimension "X"